

Engineering built smarter. Solutions built to last.

Tuboshu delivers innovative, sustainable engineering built for Africa. Backed by decades of expertise, we design adaptive, high-performance solutions that solve real operational challenges. Our commitment to quality drives every project, supported by a trusted network for maintenance, technical assistance, and ongoing after-sales service.

Elevate Your Power



TUBOSHU⁷

© 2025 Tuboshu. All Rights Reserved

tuboshu.co.uk

Certain specification(s) are based on engineering calculations and are not actual measurements. Specification(s) are provided for comparison purposes only and are subject to change without notice. Specification(s) for your individual Tuboshu equipment will vary based on normal variations in design, manufacturing, operating conditions, and other factors. Pictures of Develon units may show other than standard equipment.



EXCAVATOR⁷ TX 800

TECHNICAL SPECIFICATION

CHARACTERISTICS

Manufacturer	TUBOSHU
Model	TX800
Configuration Number	TUTZ750UK

GENERAL INFO

Operating Weight	77000 kg
Rated Power	566Kw / 1900rpm
Standard Bucket Capacity	5.0 m ³
Rock Bucket Capacity	5.0 m ³

ENGINE

Brand	WEICHA
Model	17T
Emission Standard	Tier III
Rated Power	566Kw / 1900rpm
Displacement	16.6 L

HYDRAULIC SYSTEM

Brand	KAWAZAKI
Max. Oil Flow	504 x 2 L/min
Implement Circuit	34.3 MPa
Travel Circuit	34.3 MPa
Swing Circuit	26 MPa
Pilot Circuit	3.9 MPa

SERVICE REFILL CAPACITIES

Fuel Tank	950 L
Hydraulic Oil Tank	430 L
Engine Oil	56 L

PERFORMANCE

Bucket Digging Force	398 kN
Arm Digging Force	334 kN
Swing Speed	6.5 r/min
Max. Travel Speed	4.0/2.8 km/h
Max/ Travel Force	506 kN
Gradeability	35 degrees
Ground Pressure	109 kPa
Bucket Capacity	5 m ³

DIMENSIONS (mm)

Transport Length	A	12837
Transport Width	B	4504
Height Over Cabin	C	3710
Height Over Boom (Transport)	D	4873
Upperstructure Carriage Width	E	3460
Undercarriage Width	F	4060
Track Length	G	5950
Track Width	H	650
Track Height	I	1461
Track Gauge	J	3410
Central Distance of Tumblers	K	4740
Counterweight Clearance	L	1610
Min. Clearance	M	934
Tail Swing Radius	N	4155
Boom Length	O	7000
Arm Length	P	2800

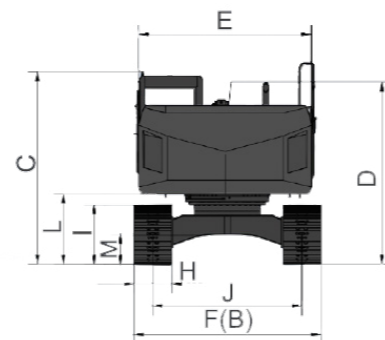
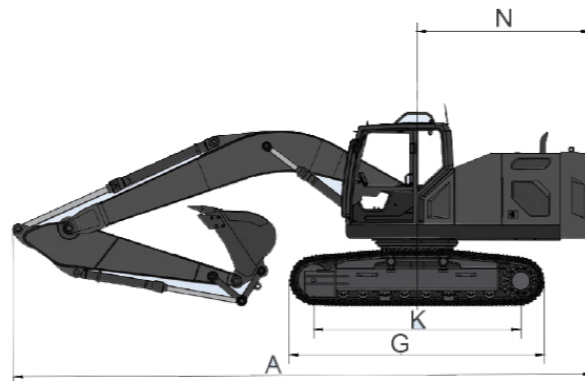

TECHNICAL SPECIFICATION

WORKING RANGE (mm)

Max. Digging Height	A	11664
Max. Digging Depth	B	7476
Max. Digging Radius	C	11980
Max. Digging Reach	D	11689
Max. Vertical Digging Depth	E	6867
Max. Dumping Height	F	7604
Min. Swing Radius	G	5271

OPTIONAL ITEMS

Breaking Hammer Line
Front Guard of Cab
800 mm Track Width

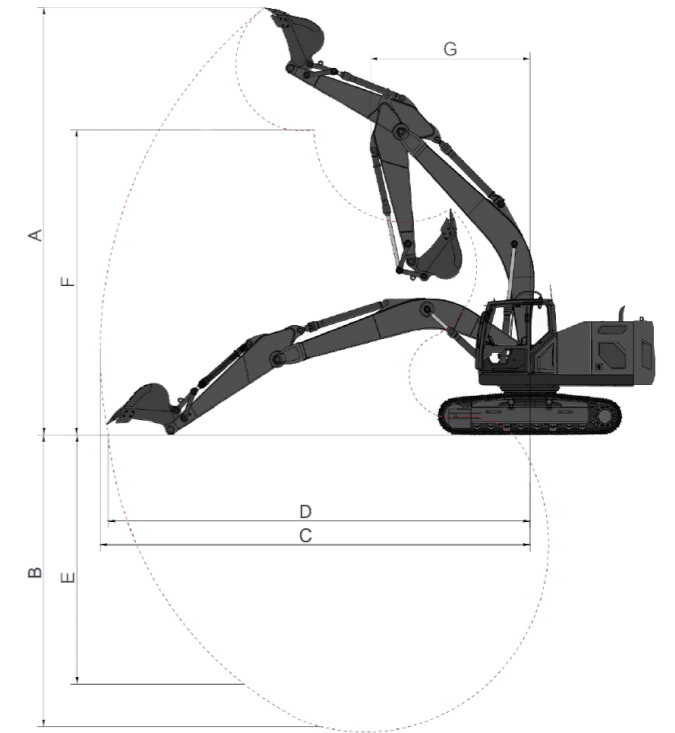

LIFTING CAPACITY

Lifting Point Height (m)	Over Front					Over Side				
	Lifting Point Radius (m)					Lifting Point Radius (m)				
	3	4.5	6	7.5	9	3	4.5	6	7.5	9
7.5				17404					14862	
6			20920	18236	16886			20920	14390	10495
4.5			23700	19583	17309			19470	13699	10229
3			26262	20951	17911			18103	12990	9876
1.5			27708	21890	18293			17188	12427	9572
Ground			27767	22056	18061			16762	12096	9405
-1.5		33501	26468	21128			27418	16711	12096	
-3	35164	29301	23517	18291		35164	27946	16992	12293	
-4.5		22285	17384				22285	17384		

